

A Method of Experimental Study of Friction in a Active System¹

L. A. Sosnovskii^a, V. V. Komissarov^{a,*}, and S. S. Shcherbakov^b

^aBelarussian State University of Transport, ul. Kirova 34, Gomel, 246050 Belarus

*e-mail: komissarov@belsut.gomel.by

^bBelarussian State University, pr. Nezavisimosti 4, Minsk, 220030 Belarus

Received April 25, 2011

Abstract—It is shown that machines of the SI series for wear-fatigue tests make it possible to measure the friction torque during rolling with a sufficient accuracy. For this purpose, methods for the calibration and determination of the accuracy of all parameters and characteristics being specified and measured are developed. A method for the determination of the coefficient of resistance to rolling depending on the value of the off-contact load is also developed and exemplified. Analysis of the experimental results and analytical description of the complex of these studies will be presented in subsequent papers.

Keywords: coefficient of resistance to rolling, test machine, test method, friction torque.

DOI: 10.3103/S1068366612020110

INTRODUCTION

For more than 150 years, specialists have attributed friction characteristics only to the influence of the contact load during motion [1–7 and many others]. This is natural since friction units are characterized by the mutual motion (rotary, translatory, reciprocal, etc.) and contact of a body and counterbody. However, in the last quarter of the 20th century, researchers came to realize that friction processes in active systems (such as rail–wheel systems) evolve “against a background” of the alternating bulk deformation of at least one of the friction members, e.g., the rail in the above-mentioned system [8–11]. The general conclusion followed from this that alternating (cyclic) deformation may vary substantially friction and wear processes. Indeed, the authors of papers [12–14] showed that cyclic stresses resulting from bending and acting in the contact zone can, depending on the operating conditions, increase or reduce the friction force and coefficient by 5–60% or more. This means that the cyclic stresses can be considered as a controlling parameter for the friction processes, on par with the contact load [8, 9]. Nevertheless, the lack of studies in this field and the problems which arise when analyzing the causes of the rail–wheel virus and operational failures of rail–wheel systems [15–18] necessitate investigation of the influence of bulk deformation on variations in the friction and wear characteristics (the back effect in tribo-fatigue [8–14]).

The aim of the study is to develop a method for the experimental study of the influence of the stresses

induced by the off-contact cyclic load on the coefficient of resistance to rolling in a shaft–roller active system, which simulates to a certain extent the basic conditions of the operation of the rail–wheel system.

MODELS UNDER TESTING

The tests to study the regularities of the effect of cyclic stresses on friction force variation during rolling were carried out using the arrangements shown in Fig. 1 (model A) and (model B). In the mechano-rolling fatigue tests (see Figs. 1b and 2b), a cylindrical specimen—a shaft fixed in the spindle of the test machine—rotates with the angular velocity ω_1 . The bending load Q is applied to its free end; it is directed upwards or downwards. A counterspecimen—the roller—is pressed to the specimen under bending in the working zone by the contact load F_N . Depending on the direction of the bending force Q , friction occurs either in the compression zone or in the tension one. In the contact fatigue tests, the bending load Q is not applied to the specimen; it is shortened to conserve material (Figs. 1a and 2a). The difference between models A and B is that cross slip is free in model A since the curvature radius $R_{22} = \infty$, while it is restricted in model B ($R_{22} = 10$ mm). An important merit of models A and B for the purpose of mechano-rolling fatigue tests (see Figs. 1b and 2b) is the possibility of the independent control over the values of the contact and cyclic—induced by bending—stresses, so that their ratio can be adjusted during tests. In addition, as it was mentioned, it is possible to implement rolling friction both in the zone of tension of the shaft being bent and in the zone of compression. A general advantage of models A and B (see Figs. 1 and 2) is that the

¹ A active system is a mechanical system in which the friction process develops in all its manifestations and which simultaneously carries and transmits an alternating load (GOST 30638–99. Tribo-Fatigue: Terms and Definitions).

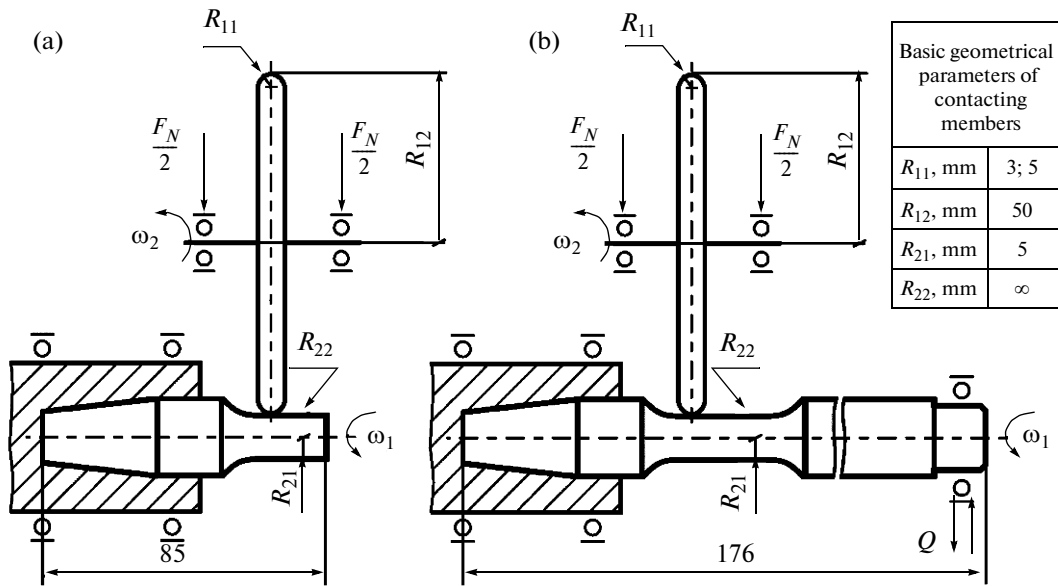

Fig. 1. Model A. Diagram of contact (a) and mechano-rolling (b) fatigue tests.

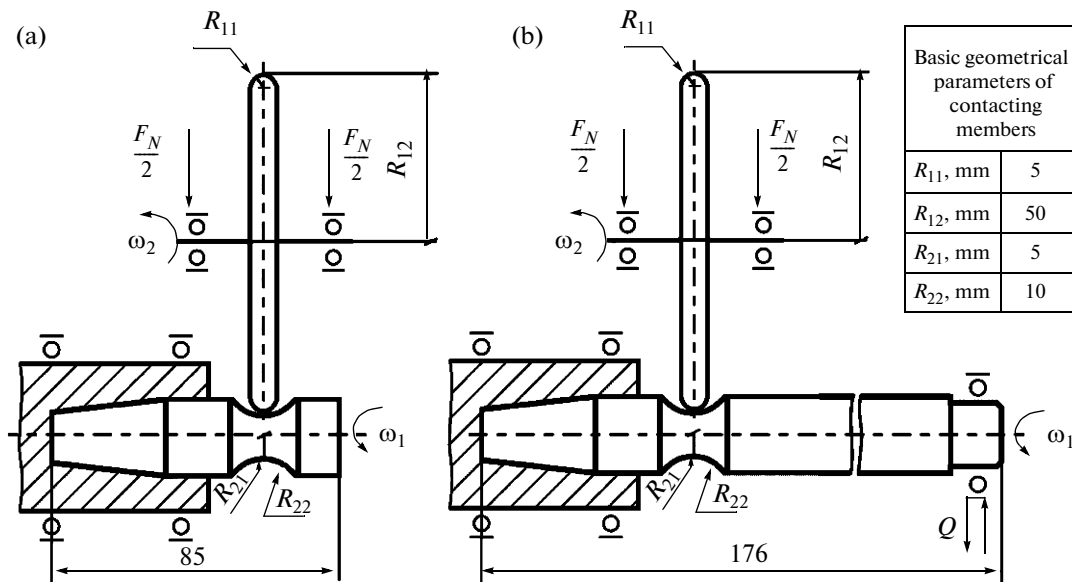

Fig. 2. Model B. Diagram of contact (a) and mechano-rolling (b) fatigue tests.

contact and mechano-rolling fatigue tests involve objects whose standard sizes in the working zone are the same. This is of crucial importance for the correct comparison of the test results obtained under different conditions.

The shafts were made of steel 45 and the rollers of steel 25KhGT. The characteristics of the materials under testing and their states are presented in the Table.

TEST METHOD AND PROCEDURE

The tests were carried out on a SI-03M machine for wear-fatigue tests (Fig. 3) at a rotation frequency of 3000 min^{-1} and the normal temperature and air humidity in accordance with GOST 15150–69. The parameters of the test machine satisfy all requirements of GOST 30755–2001 [19]. Oil TAD-171 was supplied in the contact zone drop by drop.

Characteristics of materials under testing

Material	Heat treatment	Surface hardness	Endurance limit at Torsional Bending σ_{-1} , MPa	Tensile yield point σ_y , MPa*	Tensile strength σ_t , MPa*
Steel 25KhGT	Surface hardening	700 HV	760	900	1700
Steel 45	Normalizing	470 HV	270	380	610

Note. * Reference data.

Study of the regularities of the effect of the cyclic stresses on variations in the friction characteristics during rolling involves the measurement of quite small values of the friction torque and requires a high measurement accuracy. For this purpose the friction torque meter is mounted directly on the motor shaft of the drive of the roller counterspecimen; this makes it possible to avoid bearing loss. The torque is measured by a precision T10F gage (Hottingen Baldwin Messtechnik). This gage is used for measuring dynamic torques on rotating shafts and does not include bearings and coll-rings. As a result, frictional and heat effects in the bearings are eliminated. The accuracy of the measurement of the friction torque by the gage is 0.1%. Figure 4 shows the schematic of measuring the friction torque on the SI-03M test machine.

The coefficient of resistance to rolling during the tests is calculated as follows:

$$f_r = \frac{M_{fr}}{F_N R_c}, \quad (1)$$

where M_{fr} is the measured friction torque, N m; F_N is the contact load, N; $R_c = 0.05$ m is the radius of the roller counterspecimen.

The tests on the SI-03 machine involve the full automatization of the measurement and recording of the characteristics under study. The following data are displayed on the monitor screen of the control computer: the contact load, the bending load, the approach of the axes, the friction torque, the friction temperature, the rotational velocities of the specimen and counterspecimen, the calculated slippage coeffi-



Fig. 3. General view of SI-03M universal test machine for wear-fatigue tests.

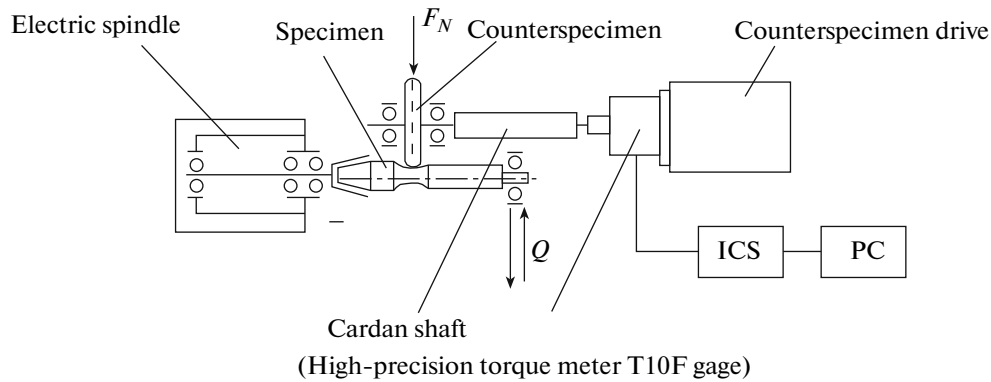

Fig. 4. Schematic of measuring friction torque on SI-03M test machine: ICS—information and control system; PC—personal computer.

cient, the test duration, the number of cycles of specimen loading, and the vibration level.

The characteristics being measured and the date and time of their recording in ascending order of the number of cycles of specimen rotation are accumulated in the database for storage and subsequent processing. On completion of the tests the measurement results are filed on the hard disc of the control computer.

All units of the test machines are checked for measurement accuracy.

(1) The test of the runout of the seat for the specimen is carried out using a 05101 detecting head mounted on the frame of the machine with a ShM-PN-8 while the shaft is rotated manually. The runout of the bore diameter of the spindle shaft should not exceed 0.05 mm.

(2) The error of the system for the counting of the total number of specimen revolutions is determined by rotating the specimen manually and taking a visual readout using the mark on the specimen. Rollback fine adjustment of the spindle is not allowed. The total number of revolutions should be no more than 100. The electric motor of the specimen drive should be switched off.

(3) The range of the rotational frequency of the specimen is checked and the error of the rotational frequency control system is determined using a 4912 instrument (Bruel & Kjaer).

The range is checked and the error is determined by the stepwise program assignment of the specimen rotational frequency in the following sequence: 600, 1000, 2000, 3000, 4000, 5000, and 6000 rpm. At least four measurements are made at each point. The measurement error of the rotational frequency should be no more than 2%.

(4) The error of the slippage coefficient control system is determined by the program variation of its value and the corresponding variation of the rotational frequencies of the specimen and counterspecimen. The error is determined at the points 0, 25, 50, and 75% at

a preset rotational frequency of the specimen drive of 3000 rpm; it should be no more than 2% of the measured value.

(5) The error of the contact load control system is determined using DOSM-3-1U and DOSM-3-2U master proving rings. Figure 5 shows the schematic for this error check. Before the check, the contact loading system is calibrated. The load is assigned in the manual control mode. The fine adjustment of the load is carried out using the rod (see Fig. 5). The measurement error of the contact load F_N is $\approx 2\%$.

(6) The error of the system of measuring the bending load is determined using the DOSM-3-1U master proving ring. The check involves the following two modes:

- when the bending load is directed “UPWARDS”;
- when the bending load is directed “DOWNWARDS”.

The arrangement of the devices and proving rings is shown in Fig. 6. Before calibration, the bending load control system is calibrated. The load is assigned in the manual control mode. The fine adjustment of the load is carried out using the rod (see Fig. 6). The accuracy of measurement of the bending load is 2%.

(7) The error of the friction torque measurement system is determined using the reference weights of the 4th class (GOST 1328–82). The arrangement of the device is shown in Fig. 7. The lever is initially equilibrated with a weight and then the friction torque meter is halted using the rod.

The check is carried out by placing reference weights of the 4th class with masses of 0.1, 0.2, 0.4, 0.6, and 0.8 kg—corresponding to friction torques of 0.5, 1.0, 2.0, 3.0, and 4.0 N m—on the plate. A weight with a mass of 0.1 kg yields a torque of 0.5 N m and that with a mass of 0.2 kg yields a torque of 1.0 N m. The length of the calibration lever arm is $L = 510$ mm. The accuracy of measuring the friction torque is 2%.

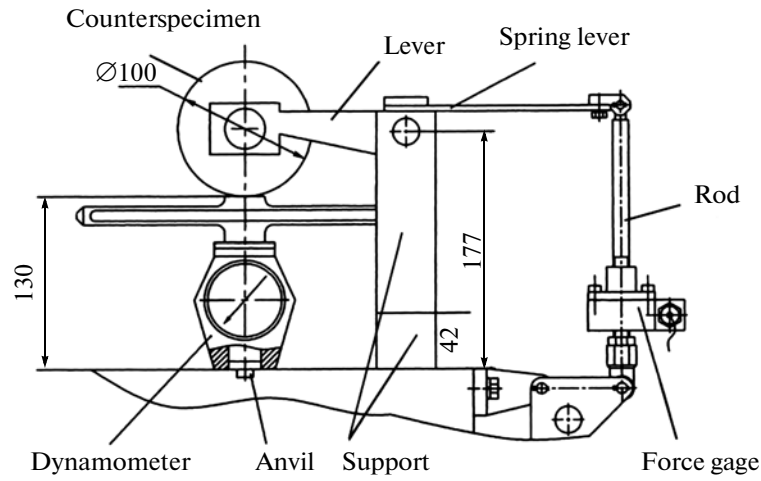

Fig. 5. Schematic of calibration of contact load control system of SI-03M test machine.

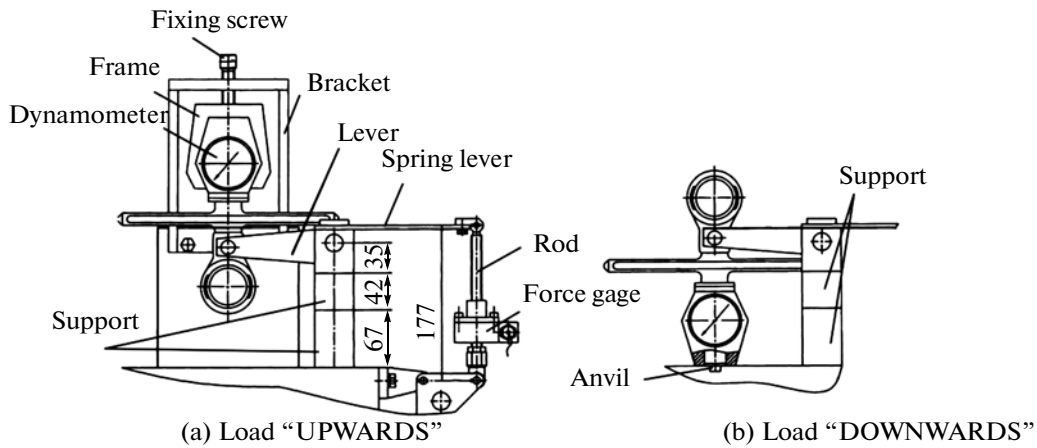

Fig. 6. Schematic of calibration of bending load control system of SI-03M test machine.

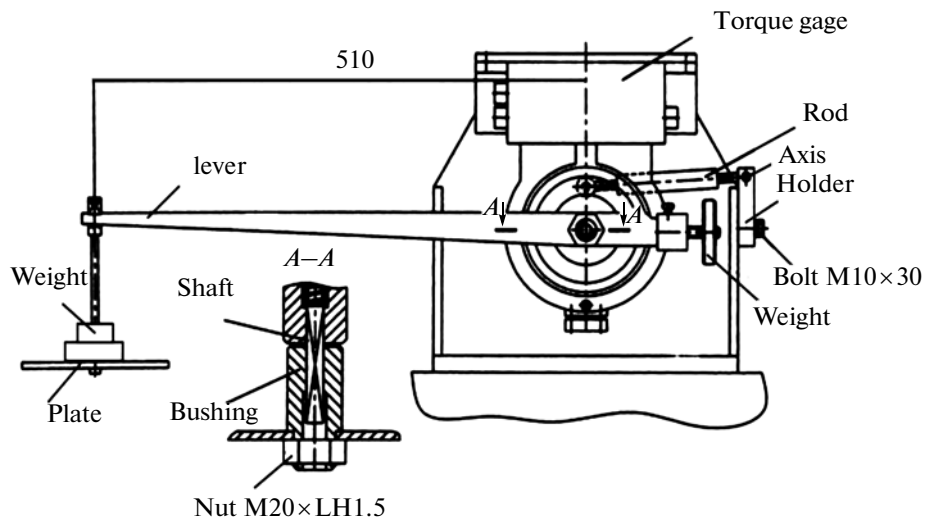

Fig. 7. Schematic of calibration of friction torque measuring system of SI-03M test machine.

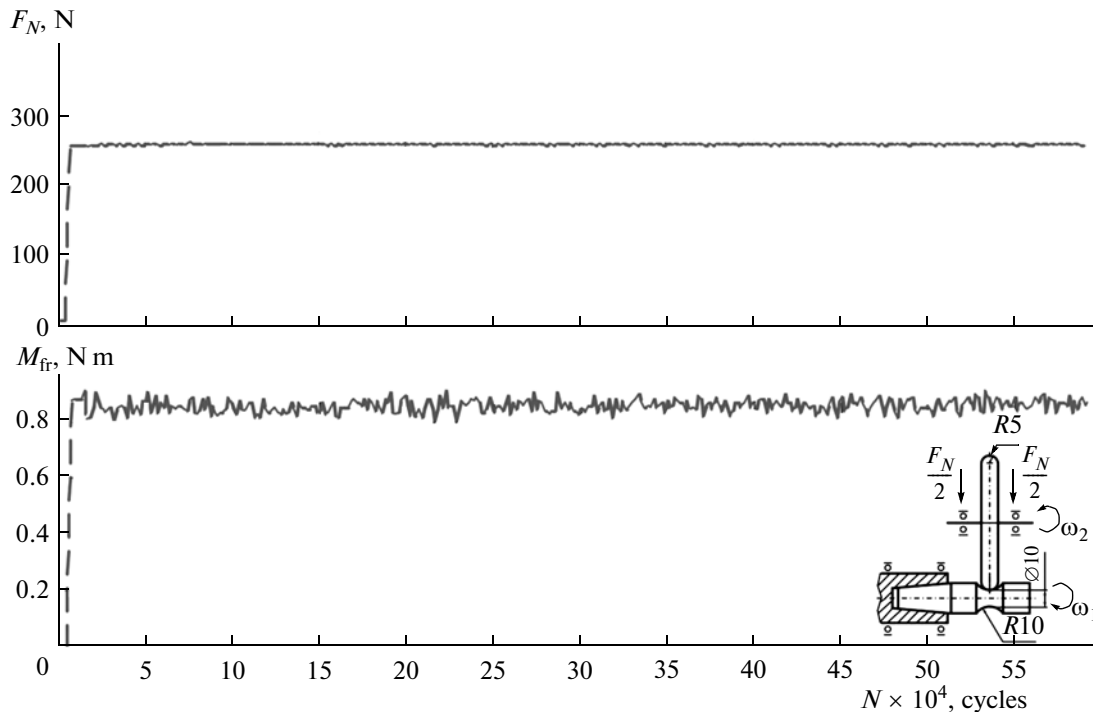

Fig. 8. Friction pair: protocol of contact fatigue tests ($\sigma_a = 0$).

We used the method of accelerated tests involving multistep loading in accordance with STB 1233–2000 [21]. Each test was repeated three times. All tests were carried out in compliance with GOST 30754–2001 [20].

Results of the Contact Fatigue Tests

An example of the loading program is shown in Fig. 8a. The contact load $F_N = 254$ N (the contact stresses are $p_0 = 2400$ MPa) is applied 2 min after the test starts. No bending load is applied in this case. It is seen that F_N remains almost constant during the test.

The results of measuring the friction torque are presented in Fig. 8b. The data show that the friction torque M_{fr} also remains almost constant during the test and amounts to 0.86 N m.

Results of the Mechano-Rolling Fatigue Tests

The tests initially involved friction in the tension zone of the shaft being bent. The loading program and the results of measuring the friction torque are presented in Fig. 9. Like during the contact fatigue tests, the contact load $F_N = 254$ N = const (the contact stresses are $p_0 = 2400$ MPa) is applied 2 min after the test starts. The bending load Q is directed downwards and applied stepwise 10 min after the beginning of the test. The initial value of the bending load is $Q = 160$ N (the amplitude of the cyclic stresses is $\sigma_a = 160$ MPa) and the increment of the amplitude of the cyclic

stresses is $\Delta\sigma_i = 40$ MPa = const at each loading step. Transitions from one step to another do not include intermediate pauses. The tests are carried out continuously until the preset number of loading cycles is reached (6×10^5 cycles). Each loading step lasts $n_i = 10^5$ cycles.

The data in Fig. 9 show that the friction torque M_{fr} declines by ≈ 0.1 N m during the test.

Then we carried out the tests in the compression zone of the shaft being bent. The loading program and the results of measuring the friction torque are presented in Fig. 10. The contact load is the same as in the previous test ($F_N = 254$ N = const; the contact stresses are $p_0 = 2400$ MPa); it is applied 2 min after the test starts. The bending load Q is directed upwards and applied stepwise 10 min after the beginning of the test. The initial value of the bending load is $Q = 160$ N (the amplitude of the cyclic stresses is $\sigma_a = 160$ MPa) and the increment of the amplitude of the cyclic stresses $\Delta\sigma_i = 40$ MPa = const. Transitions from one step to another do not include intermediate pauses. The tests are carried out continuously until the preset number of loading cycles is reached (6×10^5 cycles). Each loading step lasts $n_i = 10^5$ cycles. The data in Fig. 10 show that the friction torque M_{fr} increases from 0.85 to 0.95 N m.

Figure 11 illustrates the combination of the loading programs and the results of measuring the friction torque averaged at each loading step for all three experiments.

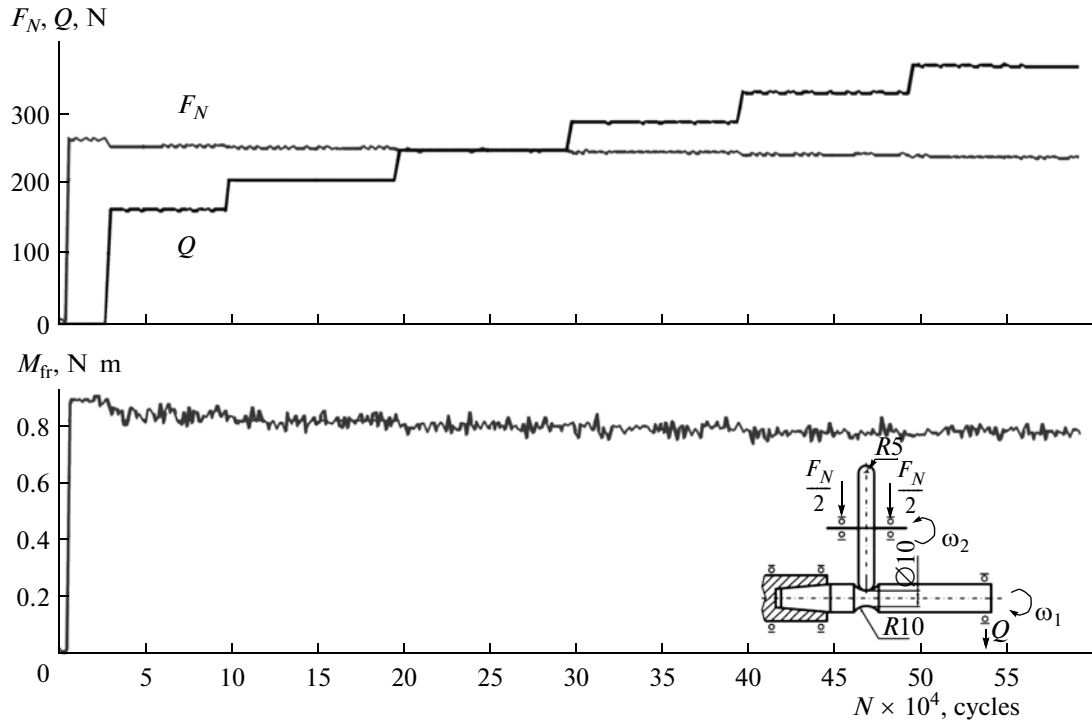

Fig. 9. Active system: protocol of mechano-rolling fatigue tests at $\sigma_a > 0$.

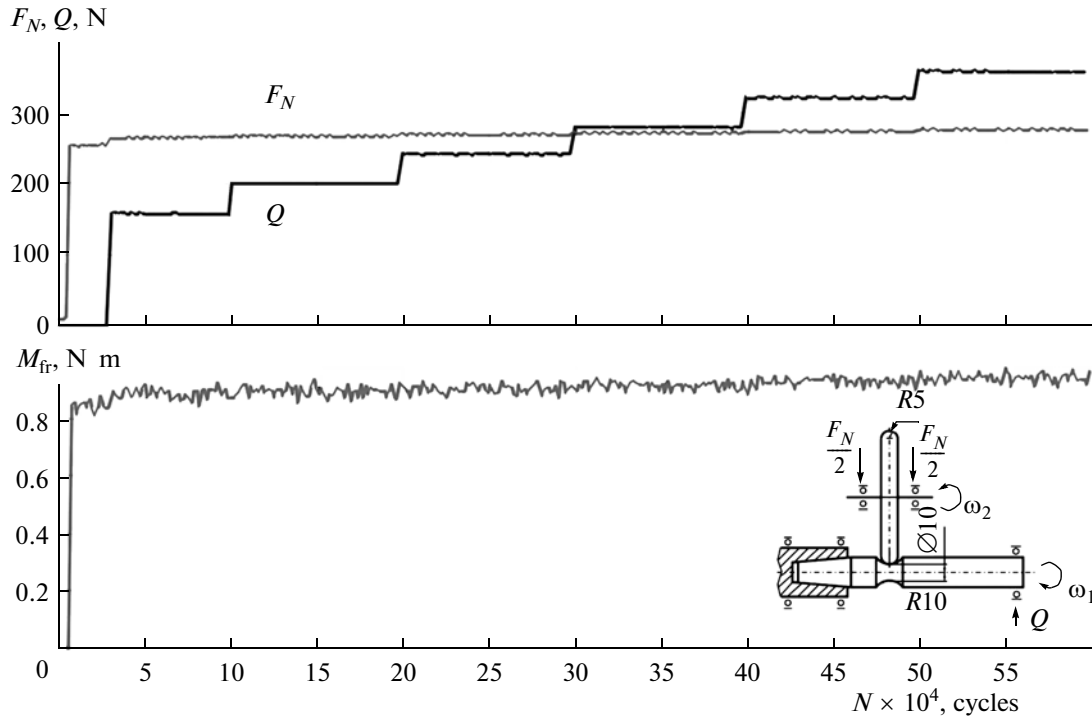

Fig. 10. Active system: protocol of mechano-rolling fatigue tests at $\sigma_a < 0$.

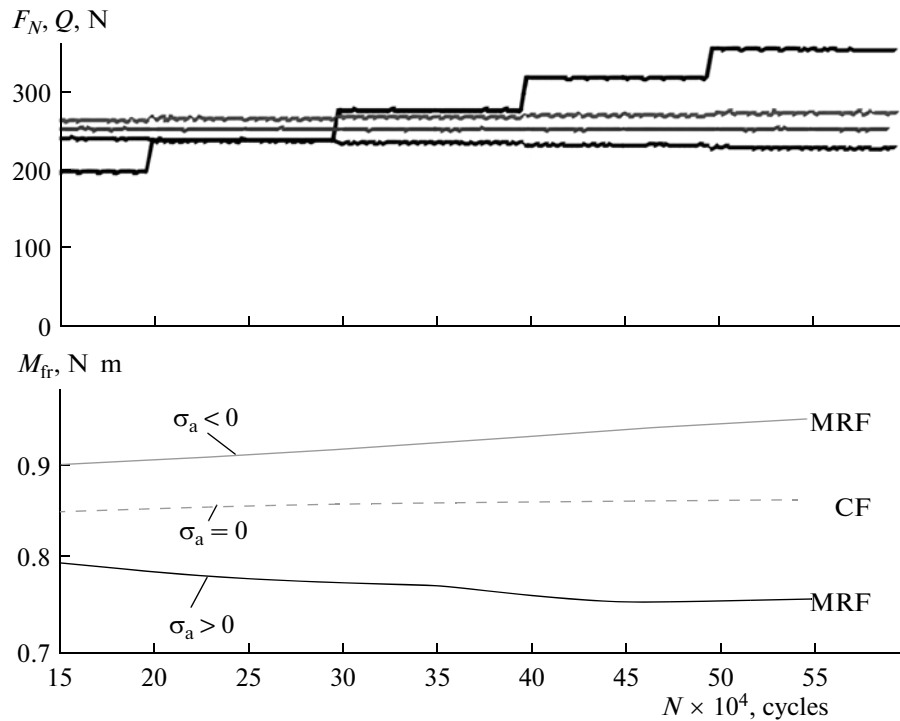

Fig. 11. Averaged protocols of contact (CF) and mechano-rolling (MRF) fatigue tests.

Figure 12 is plotted by the results of the statistical processing of the data. At each of the six loading steps with the bending load Q lasting 10^5 cycles, the friction torque is measured 66 times and its average value is measured. The latter is substituted in formula (1) to calculate the average value of the coefficient of resistance to rolling f_r . Thus, 66 values of the coefficient of resistance to rolling f_r correspond to each point in Fig. 12. This allows us to conclude that the dependence in Fig. 12 is statistically stable.

Based on the data in Figs. 11 and 12 we arrive at the following basic conclusion: if the cyclic stresses induced by the off-contact bending load are excited in the rolling friction zone at a constant contact load, then the friction torque, and therefore the coefficient of resistance to rolling, grow monotonically as the absolute value of the compressive cyclic stresses increases ($\sigma < 0$) and diminish monotonically as the tension cyclic stresses increase ($\sigma > 0$). This regularity is observed in the cases when the bending stresses are less than the bending endurance limit σ_{-1} . The dependence remains unchanged when the effective stress exceeds σ_{-1} (by 33% under the given experimental conditions). Analysis of the reasons behind this effect and its analytical description go beyond the scope of the current study; it will be reported in subsequent papers.

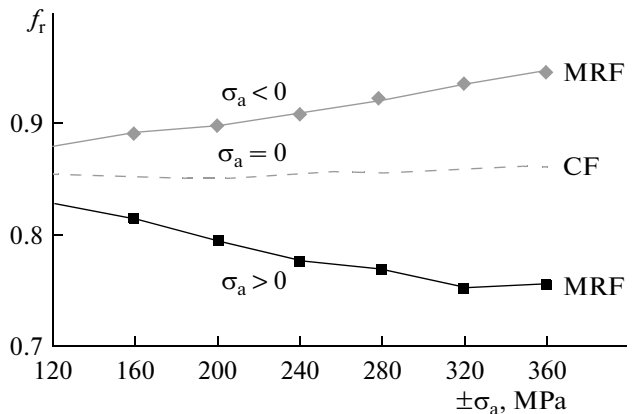

Fig. 12. Dependence of coefficient of resistance to rolling on cyclic stress amplitude.

CONCLUSIONS

The study results allow us to draw the following conclusions.

- (1) A method for studying the friction torque and the coefficient of resistance to rolling in a active system depending on the value of cyclic stresses induced by the off-contact (bending) load has been developed and tested experimentally.

The method is intended for comparative studies of the friction characteristics in a friction pair and active system involving test objects of standard dimensions.

(2) The method includes the following stages:

- check of the runout of the specimen seat;
- determination of the error of the system regarding the count of the total number of specimen revolutions;
- check of the range of the rotational frequency of the specimen and determination of the error of the rotational frequency control system;
- determination of the error of the slippage coefficient control system;
- determination of the error of the contact load control system;
- determination of the error of the bending load control system;
- determination of the error of the friction torque control system;
- contact fatigue tests of the friction pair;
- two mechano-rolling fatigue tests of the active system with the successive implementation of friction in the tension and compression zones.

(3) It is found using the method that the measurement errors for the SI-03M test machine are as follows:

- $\pm 2\%$ for the friction torque;
- $\pm 2\%$ for the bending load;
- $\pm 2\%$ for the contact load;
- up to 1 rev for the number of revolutions;
- $\pm 2\%$ for the rotational frequency and the slippage coefficient.

(4) Based on the measurement results the following basic regularity for the steel 45–steel 25KhGT active system is established: the friction torque remains practically unchanged during the contact fatigue tests and increases linearly with increasing cyclic stresses during the mechano-rolling fatigue tests if friction occurs in the compression zone or decreases if friction occurs in the tension zone.

(5) The friction torque is 0.86 N m in the case of contact fatigue and reaches 0.95 and 0.76 N m in the case of mechano-rolling fatigue at $\sigma_a = \pm 360$ MPa depending on the bending load direction; i.e., it changes by 10.6 and 11.6%, respectively. Ignoring such a change in the coefficient of resistance to rolling in the active system leads to an incorrect assessment of the serviceability of real objects.

DESIGNATIONS

F_N —contact load; f_r —coefficient of resistance to rolling; M_{fr} —friction torque; n_i —duration of loading step; p_0 —maximum contact stress; Q —bending load; R_c —radius of roller counterspecimen; σ_a —stress

amplitude; $\Delta\sigma_i$ —stress increment; ω_1 , ω_2 —angular velocities of specimen and counterspecimen, respectively.

REFERENCES

1. Bolton, P.J. and Clayton, P., Rolling-Sliding Wear Damage in Rail and Tyre Steels, *Wear*, 1984, vol. 93, pp. 144–165.
2. Bowden, F.P. and Tabor, D., *Friction: An Introduction to Tribology*, New York: Anchor Books, 1973.
3. Eadie, D.T., Santoro, M., Oldknow, K., and Oka, Y., Field Studies of the Effect of Friction Modifiers on Short Pitch Corrugation Generation, *Proc. 7th Int. Conf. on Contact Mechanics and Wear of Rail/Wheel Systems*, Brisbane: 2006, vol. 1, pp. 235–243.
4. Bushe, N.A., *Trenie, iznos i ustalost' v mashinakh* (Friction, Wear and Fatigue in Machines), Moscow: Transport, 1987.
5. Myshkin, N.K. and Petrokovets, M.I., *Tribologiya. Printsipy i prilozheniya* (Tribology. Principles and Applications), Gomel: IMMS NANB, 2002.
6. Chichinadze, A.V., Braun, E.D., Bushe, N.A., et al., *Osnovy tribologii (trenie, iznos, smazka): Uchebnik dlya tekhnicheskikh vuzov* (Fundamentals of Tribology (Friction, Wear, Lubrication). A Textbook for Technical Educational Institutes), Chichinadze, A.V., Ed., Moscow: Mashinostroenie, 2001.
7. Kragel'skii, I.V., Dobyshin, M.N., and Kombalov, V.S., *Osnovy raschetov na trenie i iznos* (Fundamentals of Calculation on Friction and Wear), Moscow: Mashinostroenie, 1977.
8. Sosnovskii, L.A., *Osnovy tribofatiki* (Fundamentals of Tribofatigue), Gomel': BelGUT, 2003.
9. Sosnovskii, L.A., *Mekhanika iznosoustalostnogo povrezhdeniya* (Mechanics of Wear-Fatigue Damage), Gomel': BelGUT, 2007.
10. Sosnovskii, L.A. and Makhutov, N.A., *Tribofatika: iznosoustalostnye povrezhdeniya v problemakh resursa i bezopasnosti mashin* (Tribofatigue: Wear-Fatigue Damages in Resource Problems and Machine Safety), Moscow: Tribofatika, 2000.
11. Sosnovskii, L.A., Troshchenko, V.T., Makhutov, N.A., et al., *Iznosoustalostnye povrezhdeniya i ikh prognozirovanie (tribofatika)* (Wear-Fatigue Damages and Their Prognosis (Tribofatigue)), Sosnovskii, L.A., Ed., Kiev: 2001.
12. Shcherbakov, S.S., Friction in Active System: Direct and Back Effect, *Tr. 4 mezhd. simp. po tribofatike (ISTF 4)* (Proc. 4th Int. Symp. on Tribofatigue (ISTF-4)), Ternopol', 2002.
13. Shcherbakov, S.S., About One Demand to Choice of Friction Coefficient in Active System, *Zavod. Labor.*, 2005, vol. 71, no. 2, pp. 46–48.
14. Tyurin, S.A., Shcherbakov, S.S., and Sosnovskii, L.A., Comparative Study of Friction Coefficients at Rolling and Mechano-Rolling Fatigue, *Zavod. Labor.*, 2005, vol. 71, no. 2, pp. 48–51.

15. Abdurashitov, A.Yu., Regularities of Mechano-Fatigue Defect Formation, *Put' i Putevoe Khozyaistvo*, 2002, no. 11, pp. 16–20.
16. Markov, D.P., Mechano-Fatigue Damage of Wheels and Rails, *Trenie Iznos*, 2002, vol. 23, no. 1, pp. 437–447.
17. Lysyuk, V.S., *Problemy iznosa koles i rel'sov* (Problems of Wheel and Rail Wear), Moscow: Transport, 1997.
18. Bogdanov, V.M. and Zakharov, S.M., Contemporary Problems of Wheel/Rail System, *Zheleznye Dorogi Mira*, 2004, no. 1, pp. 57–62.
19. GOST 30755–2001. Tribofatika. Mashiny dlya iznosoustalostnykh ispytaniy. Obshchie tekhnicheskie trebovaniya (*Mezhhgosudarstvennyi standart*) (GOST 30755–2001. Tribofatigue. Wear-Fatigue Test Machines. General Technical Demands (Interstate Standard), Minsk: Mezhhgos. Sovet po Standartizatsii, Metrologii i Sertifikatsii, 2002.
20. GOST 30754–2001. Tribofatika. Metody iznosoustalostnykh ispytaniy. Ispytaniya na kontaktno-mekhanicheskuyu ustalost' (*Mezhhgosudarstvennyi standart*) (GOST 30754–2001. Tribofatigue. Methods for Wear-Fatigue Tests. Tests on Mechano-Rolling Fatigue (Interstate Standard)), Minsk: Mezhhgos. Sovet po Standartizatsii, Metrologii i Sertifikatsii, 2002.
21. STB 1233–2000. Tribofatika. Metody iznosoustalostnykh ispytaniy. Uskorennyye ispytaniya na kontaktno-mekhanicheskuyu ustalost' (STB 1233–2000. Tribofatigue. Methods for Wear-Fatigue Tests. Accelerated Tests on Mechano-Rolling Fatigue), Minsk: Belarus. Inst. Standartizatsii i Sertifikatsii, 2007.